

Steeda GT500 3.4L Idler Pulley

Installation Instructions for 555-3354

Kit Contents

- 1 Billet idler pulley bracket
- 1 Billet idler pulley assembly
- 1 Steel slider block
- 3 M6x90 Socket head cap screw
- 3 M6 flat washer
- 1 M10 x 50 Nylon tipped set screw
- 1 M10 x 45 Hex flange head bolt
- 1 M10 flat washer
- 1 M10 Jam nut

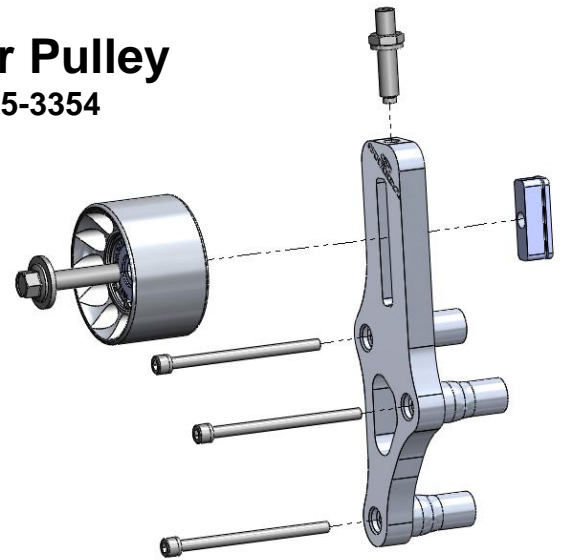

Installation Instructions

1. Ensure that engine/coolant system has cooled down. Remove the 2 screws that hold the coolant reservoir to the radiator support. Place reservoir to the side on top of the radiator cover to give yourself some working room at the front of the engine. Slightly loosen the reservoir cap to vent any remaining pressure and tighten when it has finished venting. Warning note: If the cooling system is warm/hot, it can spray hot coolant from the reservoir when vented. Allowing the system to cool down to room temperature will reduce the chance of injury.
2. Using a breaker bar of the appropriate size, detension the supercharger belt and slip it off of the supercharger pulley. Tuck the belt between the radiator hose and the heat exchanger reservoir hose.



3. Remove the 3 coolant outlet bolts circled in the picture.
4. Slide an M6 washer onto each of the 3 M6 bolts and slide the bolts into the 3 counter-bored holes in the pulley bracket.
5. With the Steeda logo up and toward the passenger's side, install the bracket onto the coolant outlet. Tighten the 3 bolts to 12 ft-lbs.

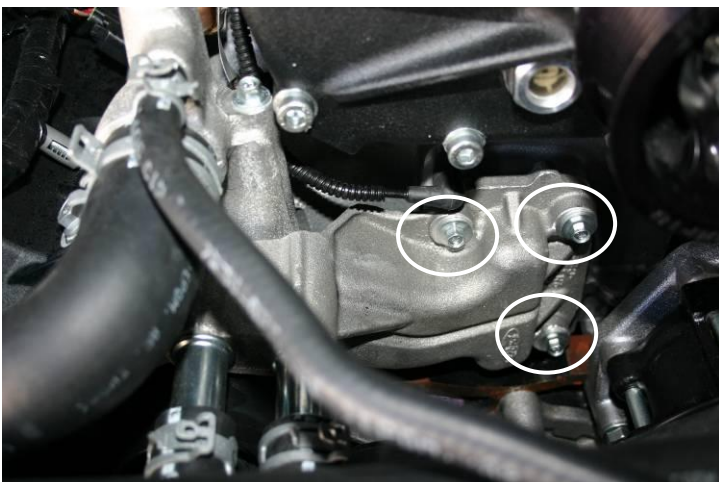

6. From the rear and below the compressor case, insert the slide bracket into the bracket slot.

7. Using the M10 x 45 bolt and the larger washer, attach the idler pulley assembly to the slide block installed in Step 6. If the slide block has 3 holes, use the middle hole. Snug the bolt down but leave it just loose enough that you can slide it up and down the slot.
8. Rotate the factory belt tensioner with the breaker bar and install the belt onto the upper supercharger pulley. Ensure that the belt is routed and seated correctly on the AC pulley, the existing pulleys, and the new pulley.



9. Insert the nylon-tipped set screw into the hole on the top face of the bracket at the end of the slot. Tighten this screw until there is approximately 5/8" space between the inner belt runs.
10. Slide the narrow M10 washer and M10 jam nut onto the set screw and tighten down the jam nut to lock the adjuster into place.
11. Tighten the M10 pulley bolt.
12. Return the coolant reservoir and secure with the factory screws.

